

adt-audio

Installation Manual

**Part I:
General Information
Power Supply Units
Audio Installation**



Version 1.22/04 • English

analoge + digitale Tonstudioteknik Karl Jüngling • Inh. Dipl.-Ing. Gerd Jüngling
Scholtwiese 4-6 • D45966 Gladbeck • Germany • Phone: 0(049) 2043 51061 • Fax: 0(049) 2043 56844
E-Mail: info@adt-audio.com • Internet: www.adt-audio.com www.broadcast-console.com

Summary

1. Power supply— 4

- 1.1 Power supply units— 5;
- 1.2 Power supply installation— 6;
- 1.3 Fail-safe Power Supply— 8;
- 1.4 The Mains Power Supply of Audio Systems— 9
- 1.5 Power Supply Connections - Power Supply Unit - Console— 12
- 1.6 The pinning of the power supply plugs— 13

2. Audio Installation in the Studio— 15

- 2.1 Grounding— 15
- 2.2 Common grounding problems— 17
- 2.3 Cables— 18
- 2.4 Planning of the installation— 19

Preface

This manual contains all the information that is necessary to prepare and plan the installation of the mixing console and accessory components.

Please, read this manual carefully. We point out common mistakes and problems that are connected with the installation and provide suggestions to avoid such problems. You will save a lot of time and unnecessary start up problems by investing a couple of hours in the reading of this manual.

The first part of the manual contains everything about the power supply units and crossover devices that are necessary for fail safe power supply configurations and the implementation of the mains connections. Part 2 is about the audio installation. Besides detailed information about basic principles of audio installation and the methods of grounding, this chapter contains all pinning diagrams, pictures and graphics about the locations of the connectors, and a detailed description of their functions.

Part 3 contains general information about the frame, the assembly of the console, environmental considerations, the recommended maintenance, and a couple of remarks about the operation of the console to ensure a long and problem free lifespan.

This manual concerns the stereo version of the BC4 broadcast console system, rev. 1.2

1. Power supply

1.1 Power supply units

Several different versions of the power supply units are available, the UPS600, UPS1000, UPS1500, UPS10 and UPS25. While the UPS600 is used for mixers with up to 24 modules in total, the



Abb. 1 - Power Supply Units UPS600 a. UPS1000

UPS1000 can be used with BC3 on-air mixers with up to 48 modules. For larger consoles, the power supply and most of the versions of the BC4 console system, the UPS1500 is used. In addition, the UPS10 and UPS25 of the 5MT series of broadcast consoles can be adapted since all the required voltages are the same in both systems.

The UPS600, UPS1000 and the UPS1500 differ in the current capacity of the main supply voltages for audio and relays. The total output power is 600 VA for the UPS600, 1000 VA for the UPS1000 and 1500 VA for the UPS1500. While the UPS600 and UPS1000 use the same housing and the same connectors, the UPS1500 is deeper and uses a different connector. Of course, a UPS1000 or UPS1500 can be used with a small size broadcast console as well. The actual power requirement of a particular mixing console depends not only on the number of channels but also on the channel and group versions used. It is obvious that modules with built in dynamic sections or other, additional features have a higher current consumption. The limits mentioned above are valid in good approximation. Of course, we determine the required power supply for every quotation and offer a device with sufficient spare capacity. We recommend, that you use a larger power supply version if the installation and/or the mains supply is critical to ensure trouble free operation.

The power supply units can be rack-mounted if the rack is stable enough to carry the weight of approx. 15 kg (30 lb) for the UPS600 and 30 kg (60 lb) for the UPS1500. The total width of the front panel is 483 mm. The actual width behind the top plate is, 320 mm for both the UPS600 and UPS1000, Without attached connectors both power supply units are approx. 210 mm deep. The height of the unit is 210 mm in total. It fits into five rack spaces. The UPS1500 fits into seven rack spaces and the depth is 450 mm without attached connectors.

Not all power supply versions have forced ventilation (fans). The two large heat sinks on both sides of the housing will dissipate heat sufficiently if

TYP	Power Consumption	Height & Depth
UPS600	600VA	220 x 210 mm
UPS1000	1000VA	220 x 210 mm
UPS1500	1500VA	320 x 450 mm
UPS10	1700VA	320 x 450 mm
UPS25	4200VA	420 x 450 mm

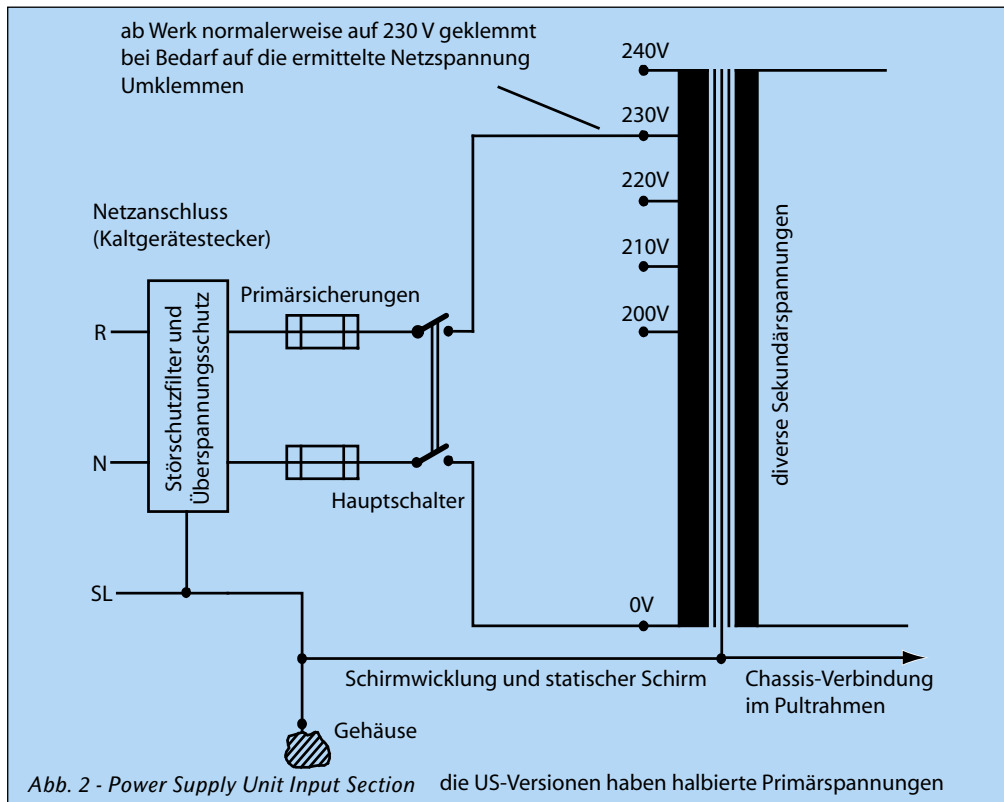

the device is correctly installed. If the unit is mounted in a closed rack, or if there are other circumstances that impede sufficient air supply, the capacity of the power supply unit will diminish. All housings are prepared for the installation of additional fans that can be installed in situations like this to force the airflow across the heat sinks and improve the heat dissipation.

All connectors are mounted on the rear panel of the devices. The mains connector is a standard Euro outlet with built in mains fuses and interference trap for the UPS600/UPS1000 and a Neutrik, Power Con connector with the UPS15000. The output is a 20-pin 'Siemens' type female multipin connector, DIN41618/622 for the UPS600/1000 and a 26-pin version of the same series for the UPS1500. The 26 pin versions

parallels the high current pins. Even though the units have different connector types, the voltages are not different. A UPS1000 can be used for a BC4 system with a special cable. The cable power supply - console belongs to the console's accessories kit. The standard length of this cable is 6 m. Cables up to 12 m are available. For cables longer than 20 m, a cable with a higher cross section is required; please ask.

All power supply units are available in two versions for 230 V and 115 V. The mains frequency can be 50 or 60 Hz with both versions. The power transformer has a tapped primary winding that makes it possible to adjust the power supply to the local mains voltage in steps of 10 V from 200 to



240 V with the 230 V version and in steps of 5 V from 100 to 120 V with the 115 V version. The minimum mains voltage depends on this settings. The tapped primary windings offer the choice to avoid unnecessary thermal stress, caused by a very high mains voltage. It is possible to find an appropriate compromise between regulation reserve and heat dissipation easily.

If you need a selectable mains voltage 230/115 V, please ask.

For fail-safe operation a second, identical power supply and an additional crossover device are used. See the chapter below for details.

1.2 Power supply installation

Even though the installation of the power supply devices of the BC4 Broadcast Console is not critical, some important things have to be considered to prevent unnecessary problems and to ensure a problem free operation of the entire system.

Thermal Considerations

Since all power supply devices of the BC4 broadcast console do not necessarily need forced ventilation, special care must be taken in regards to the airflow with the installation of the units. The major part of the heat exchange takes place at the heat sinks mounted on both sides of the power supply unit. It is crucial that cold air can pass along the heat sink unimpeded. Air inlets should be placed below the unit, underneath the heat sink and corresponding air outlets have to be above the heat sinks. If the units are mounted in a rack, this might be a problem, even more if additional devices with high heat dissipation are mounted in the same rack. The best way to avoid problems due to inappropriate heat removal is to leave an appropriate free space of 2 or 3 rack spaces between the particular devices. In addition, no unit should be installed at the extreme bottom of the rack. To force a good distribution of cold air, it is a good practice to leave 3 rack spaces free at the bottom of the rack.

If the power supply unit is not installed in a rack but used stand-alone on the floor, care must be taken, that there is at least 5 cm / 2" of free space between the bottom of the unit and the floor. If this space is too small or even not existing, air cannot pass thru the device from bottom to top.

This causes limited heat dissipation and might considerably reduce the capacity of the power supply unit. Spacers are available for this purpose; a wooden slat of about 5 cm height is a sufficient solution as well. A higher distance to the ground is even better, of course. If the unit is placed next to a wall or in a corner, we recommend, that the distance to any wall is at least 5 cm / 2". This rule is either valid for an additional cover plate above the unit. We recommend that you use such a plate to prevent conductive parts, pieces of wires, aluminum foils or any other conductive material to fall into the device thru the slotted cover sheet of the unit. If you use a cover plate, take care that the distance between the top of the unit and the additional cover plate is at least 5 cm.

If the circumstances at the place of installation do not allow applying the principles listed above, there are a couple of ways to ensure trouble free installation even though.

Rack-mounted Fan(s)

Installing and using rack-mounted fans is a good decision, if other devices with a high heat emission are installed in the same rack as the power supply unit. One or two fan units can be used. If one unit is used, it should be mounted at the top of the rack. The direction of the fans must transport hot air out of the rack. Adding a second fan would improve the airflow even more. This second unit should be installed on the bottom of the rack in a way, that it blows cold air into the rack. It is a good idea to use a fan unit with an integrated dust filter. The filter will decrease the dust pollution in the rack. However, a filter requires continuous maintenance.

Like all fan-cooled systems, the reliability of the cooled devices depends on the reliability of the fans. If the fans fail, the entire system will fail. The best way to make sure that a fan cooled system is safe to operate, is to install at least twice the number of fans that are necessary for normal operation. This principle ensures that a failure of one or two fans will not cause total failure.

Fans in the Power Supply Unit

Internal fans are possible for all power supply units of the BC4 Broadcast Consoles. If specified with the order the power supply comes with fans installed. However, it is possible to upgrade the power supply units with fans at any time, since all units come with all necessary mounting holes. Power supply units with installed fans require free airflow at the rear side

of the unit. If the installation does not cater for the free expulsion of the hot air, the fan is almost pointless. However, if free airflow is possible, the heat sink temperature will be reduced from 10 to 20 degrees. The cooling effect of external, rack-mounted, fan units is more even. If at all possible, these units should be used. Since any fan produces noise, if the power supply is installed in the control room this might eliminate the use of fans.

High capacity Power Supply Unit

In principle, a power supply unit with a higher capacity reduces the temperature of the heat sinks; however, the quantity of heat produced is eventually the same, as it depends not on the capacity of the power supply unit but the broadcast console. Therefore, there is no advantage to use a UPS1500 instead of a UPS1000. The cooling load is not different; therefore, a stronger power supply than necessary for the particular broadcast mixer will not substitute appropriate and sufficient ventilation.

Test of the Installation

A good method to test the installation of the power supply unit is to check the temperature after some hours of operation. If the temperature exceeds 60°C, cooling is insufficient. You can make a quick test just by touching the heat sinks with your hand. If the temperature is above 60°C, you will jerk back immediately. A temperature of 50°C, which is appropriate, gives you the feeling that it's rather warm but not hot.

Mains Voltage

The power supply units are available for a power voltage of 230 V or 115 V. The transformer of the unit has a tapped primary winding that makes it possible to adapt the unit to 200, 210, 220, 230, or 240 V mains voltage for the 230 V versions and to 100, 105, 110, 115, and 120V for the 115 V versions. It is possible to adjust the power supply exactly to the local situation. The terminator block is accessible after the cover sheet is removed.

**FOR SAFETY REASONS YOU MUST DISCONNECT THE MAINS BEFORE OPENING THE UNIT.
PLEASE CONSIDER - HAZARDOUS VOLTAGES INSIDE THE POWER SUPPLY ARE A RISK FOR YOUR HEALTH AND YOUR LIFE.**

**MAKE SURE THAT ANYTHING THAT FALLS INTO THE UNIT (SCREWS OR OTHER METAL PARTS ETC.) IS REMOVED BEFORE THE UNIT IS RECONNECTED TO THE MAINS.
THE COVER SHEETS MAY HAVE SHARP EDGES, ACT CAREFULLY, ONLY QUALIFIED PERSONNEL WITH KNOWLEDGE ABOUT ELECTRICAL SAFETY ARE ALLOWED TO MODIFY OR REPAIR THE POWER SUPPLY UNITS.**

The terminals for the primary voltage settings are clearly marked inside the power supply unit either on the mains transformer for the UPS600/1000 versions or on a separate terminal block for the UPS1500. Make sure that you do not change any other wiring than the tapped primary winding.

Please consider:

Setting the mains voltage to a lower voltage tap of the transformer increases the output voltage of the transformer and therefore the regulation reserve. At the same time higher heat dissipation occurs. You should do this if there are problems with a mains voltage that is too low. In this case, remove the mains power from 230 V and connect it to 220 V or from 115 V to 110 V respectively

Setting the mains voltage to a higher voltage tap of the transformer decreases the output voltage of the transformer and therefore the regulation reserve. At the same time LOWER heat dissipation occurs. You should do this if the mains voltage is very high all the time (240 V, for example) and the temperature of the power supply is very high. In this case, remove the mains power from 230V and connect it to 240 V or from 115V to 120 V respectively.

The better the primary setting of the power supply unit is adapted to the local situation, the less heat is dissipated. Depending on the stability of mains voltage it is possible to find an appropriate compromise between regulation reserve and heat dissipation.

In most cases, it is not necessary that you take care about the setting of the primary voltage. We deliver all power supply units with a default setting of 230 V or 115V respectively. This setting will result in a good compromise for most local situations. However, if the mains voltage is

always very high or very low, or if there are large voltage swings in the mains power, it can be of advantage to check if another primary setting is the better choice. Two problems might arise because of an inappropriate setting of the primary voltage, very high heat dissipation and drop out failures.

If the line voltage is very high, the regulation reserve of the power supply that makes sure that the internal voltage regulators operate with low mains voltage too, is much too high. This results in a high voltage across the voltage regulator, therefore in a high power that causes higher heat dissipation.

If the line voltage is very low, the regulation reserve is not sufficient to assure proper operation of the voltage regulators. The heat dissipation is very low, however, as soon as the mains voltage drops below the regulator's drop out point, a 100Hz or 120 Hz interference appears on the DC output voltage. This AC component will cause a hum noise of approximately - 50 dB in all master outputs of the broadcast console; the solution is to use a different setting for the primary voltage. It is best to test the mains voltage every couple of hours for several days before making any changes. Make a note of the values, and after a few days check for the highest and the lowest value. Then change the setting -

AFTER YOU HAVE DISCONNECTED THE MAINS – FOLLOW THE SAFETY RULES LISTED ABOVE!

To a setting, that is the next lower value to the lowest value on your list. If your lowest value is 223 V, you are supposed to use transformer tap 220 V, for example. Now, check the highest value on your list. If it is lower than the lowest value + 10 V, you are done. If not, it is necessary to check the temperature of the power supply unit every once in a while for a couple of days. If the temperature exceeds 60°C for several hours, you should improve the ventilation of the power supply (outside the rack, some free rack spaces above and below the power supply, or a change of location).

1.3 Fail-safe Power Supply

The C1000 C1500 crossover units are optionally available if failsafe operation is required for BC4 on-air consoles. This unit can be used with all the power supply units UPS600, UPS1000 and UPS1500. The failsafe device is a passive diode cross over with an additional, active, failure response system. The C1000 and C1500 cross over units are equipped with Shottky diodes with very low drop out voltage to keep voltage drop and power dissipation of the failsafe system as low as possible. A connector for a remote display that can be installed in the console's meter bridge is available.

The passive diode cross over section of the C1000 and C1500 failsafe units can handle forward currents of up to 10 or 20 ampere per output voltage for the C1000 or C1500 version, therefore the operation with any of the standard power supply units of the BC4 broadcast consoles is possible.

The cross over unit is a 3U high rack mountable device. The total width of the front panel 483 mm. The actual width behind the top plate is 440 mm. Without attached connectors the C1000 and C1500 are approx. 320 mm deep. The only differences between the C1000 and C1500 version are the current of the diodes and the type of connectors that is used. While the C1000 uses diodes for a current load of 10 amps and a 20-pin connector,



Abb. 4 - Failsafe Power Supply - Crossover-Unit C1000

the C1500 uses diodes for currents of 20 amps and a 26-pin connector. The pinning is same as it is used with the power supply units.

Due to the low drop Shottky type power diodes, the power and heat dissipation of the C1000 cross over unit is rather low, even under full load condition. Additional ventilation is not required and the installation is not critical as far as the airflow is concerned.

All connectors are mounted on the rear panel of the device. The mains connector is a standard Euro outlet with build in mains fuses and interference trap. The output is a 20 pin or 26 pins 'Siemens' type female multipin connector. The device has two inputs for the two power supply units UPS1000, UPS600 or UP1500 respectively. The input connectors are 20 pin or 26 pin 'Siemens' type male multipin connectors. Two cables to connect the power supplies 1 and 2 to the cross over unit belong to the console's accessories kit. The standard length of these cables is 2 m. Longer cables are available.

Since the diode matrix is passive, mains supply is only required for the alert system. However, the alert system of the device requires a power supply. The power consumption of all versions is only 30 VA. The mains transformer can be used with 230 V and 115 V. Solder bridges inside the unit determine the mains voltage.

The failure alert system controls if all output voltages of both attached power supply units have a sufficient output voltage. LED's on the top plate of the cross over unit indicate the output voltages. A minimum voltage can be adjusted for each voltage independently, using internal trim pots. If at least one output voltage drops below the minimum voltage, an alert LED displays failure condition. In addition, a beeper is activated. The beeper can be switched off on the top plate of the device.

A Remote Panel that contains the 2 failure alert lamps, an alert beeper and a switch to disable the beeper but not the lamps is available. This panel can be installed in the meter bridge of the console to ensure permanent control of the power supply section if the power supply units are installed in a separate room. An additional control cable is needed for this remote section.

1.4 The Mains Power Supply of Audio Systems

ONLY QUALIFIED PERSONNEL SHOULD BE ALLOWED TO INSTALL AND/OR MODIFY HAZARDOUS VOLTAGE, ELECTRICAL SYSTEMS.

THE EXAMPLES WE GIVE ARE VERY GENERAL AND ARE TO BE TAKEN AS SUCH; IN ADDITION, SOME DETAILS MAY NOT APPLY IN YOUR LOCAL AREA BECAUSE OF SPECIFIC LOCAL LAWS AND/OR REGULATIONS.

WE ADVISES THAT YOU CONSULT A QUALIFIED ELECTRICIAN REGARDING THE INSTALLATION OF ANY NEW ELECTRICAL SUPPLY, OR THE MODIFICATION OF AN EXISTING SUPPLY. BY NO MEANS, WILL WE BE LIABLE FOR ANYTHING THAT YOU DO.

As far as the mains power supply of a professional audio system is concerned, it is possible to avoid many problems from the very beginning by correctly installing the studio system. Besides click noise by other electrical devices and other problems due to mutual interacting of two devices that share the same power supply, the grounding of the audio system is unavoidable connected to the power supply. A correct grounding of the entire system can only be accomplished if the safety grounding that is used at the location is properly integrated to cover all considerations. If this is neglected, the final installation will never be problem free.

Power supply wiring

The best base for an appropriate installation of the studio is that a separate three phase current line is available that is used only for the studio. This line should come directly from the main ground node of the building and it should have an appropriate cross-section of $4 \times 10\text{mm}^2$ or higher. This line should be available in a distribution in the studio. This principle avoids any kind of interference from other electric devices that share the same power and ground and can cause interference in the system. Typical examples are refrigerators, electric heater systems or coffee machines with poor suppression filters that can infiltrate click noise or Xerox machines that use switched mode heat regulators that scatter

back RF noise. Even though the input filters of the console's power supply units and an additional, totally separated screen winding of the mains transformer will block these disturbances as far as the console's DC supply is concerned, the problem remains, since the only possible way to shunt these disturbances is the ground.

In addition, the separate line is the best way to control the audio grounding of the system. Usually, the mains line is carried out as a 4-conductor line with 3 phases and the neutral conductor. Even though there are different rules and uses from country to country, this is a commonly used principle that works fine as far as safety is concerned, but not for audio. Since the neutral conductor is not totally separated from the protection conductor that is used to maintain electrical safety in different ways in most countries, an unbalanced load of the three-phase conductor causes compensation current in the neutral conductor. Of course, this current causes a voltage drop on the line that shifts the entire ground potential away from that potential that can be considered as ground node. In principle, the only 'real' ground node is the core of the planet; however, a real-world ground node is an electrical potential that is not different from the electrical potential of another place, independent of the distance between the two points. All these or limit considerations, of course. Let's get back to 'ground'. The point in a building that comes closest to this ground node, is the mains power entry, where the neutral connector is bridged to an earth plate, the concrete of the buildings foundations, the main water pipes and other systems that are supposed to have a very good 'earth' connection. The closer (in the electrical meaning of this word) that you can come to this potential, the less are your grounding problems. It is therefore crucial to have this electrical potential transported to the main ground node of the entire studio.

If a conventional 4-line cable is used, the ground potential depends on the current in the neutral connector. There is no way to avoid this current, since almost no audio equipment uses a three-phase power supply. It is simply not possible to share all equipment between the three phases in a way that the resulting current in the neutral conductor is zero. The result of these considerations is that a separate, current free conductor must be used for ground. If the mains supply line is implemented as a five-line cable that uses an additional conductor only for the ground, you

don't need to take care about this; it's already done. However; with a 4 line cable, it is very important to install an additional line that is current free and transports the ground node potential from the 'low impedance point', which is usually the mains distribution in the basement of the building. This line should have the highest possible cross section that can be installed. 10 mm is a minimum, 16, 20 or even 32 mm will do no harm but improve the stability of the system. We will see later, that this line is actually not current free but has to shunt all interferences that are injected into the ground by the connected devices.

Let's get this clear. If the ground is connected thru a separate line from the basement that has a cross section of 10 mm², the resistance of this line is approx. 1.7 milli ohms per meter. With a cable length of 50 m, there is a total resistance of 85 milli ohms. If we use one phase of the three phase system for all the audio equipment and the second and third phases for 'dirty' electric stuff, like lamps, heaters and whatever else is installed we can assume that we will have a final current in the neutral contactor of something in the range of several amperes. Let's start with the assumption that the compensation current is 5 amperes, which is a realistic value. Simply using 'Ohm's Law', it is obvious that this current causes a voltage drop of 5 amps * 0.085 ohms, which is approximately 0.4 Volts. As long as the complete studio system is completely isolated from the rest of the world, this is not a problem. However, if there is only ONE ground connection to another room or studio that has a different ground potential, a compensating current will flow thru this additional connection and cause problems. The voltage drop on the ground line is of course an alternating voltage with the frequency of the local mains voltage, 50 or 60 Hz. It therefore injects an audible hum into the system that changes as soon as the ground potential of one of the systems changes. This problem is well known as a 'ground loop'.

RF problems

Most of the modern devices use a switch mode power supply section that is more efficient than conventional linear power regulators. This principle allows easier control over the power dissipation but it produces high-level interferences at the switching frequency of the regulator, which is in the range between 40 kHz and 100 kHz with most devices. Since the switching regulator does not produce clean sine waves, many additional harmonics

are produced as well. There are several different types of switch mode regulators that produce different sorts of interferences, but for our problem, this is not important. What is important is that every device has a built in RF filter whose job it is to avoid the reaction on the power line. Of course, the protective connector is used to leak the RF interference. This adds a considerable amount of RF current into any ground system that can cause many strange problems. While a 50 or 60 Hz voltage offset on the ground system will be different in several parts of an audio system in the same room if all the units are ground connected using appropriate cross section lines, the RF signal can spread out much easier. The voltage drop depends not only on the real resistance of the ground connections but also on the inductive reactance of the wires that is proportional to the frequency. It is almost impossible to make realistic calculations. The only remedy is to increase the cross section of the ground cables that ground all parts of the audio system. The higher the cross section is the 'closer' is each device to ground and the lower is the probability that RF signals are injected into the ground system.

Neutral connector

In some countries, it is common to connect both the protective conductor and the neutral conductor in the power distribution panel. As far as safety considerations are concerned this works fine, as far as audio grounding is concerned, this method spoils the entire system described above. If there is a connection between the neutral conductor and the separate ground line, the ground line is ineffective, because it is just a parallel line to the neutral connector. Please, make sure that this is not the case with your installation.

Let's put this together:

The base of a problem free installation of the entire studio system is a solid, high cross section ground that is directly connected to a low impedance ground node, which is in most cases the mains power entry in the basement of a building. This main audio ground should be used to connect the electric ground and protective ground of all devices in the studio with high cross section cable. Care must be taken that the ground connector is isolated from the neutral conductor.

ONLY QUALIFIED PERSONNEL SHOULD INSTALL OR MODIFY ANY ELECTRICAL SYSTEM. MISTAKES AND/OR NEGLIGENCE CAN CREATE LIFE THREATENING SAFETY HAZZARDS. UNDER NO CIRCUMSTANCE SHOULD UNQUALIFIED PERSONNEL TOUCH THESE CIRCUITS – LIFE IS IN DANGER IF SAFETY RULES ARE NOT FOLLOWED.

Assignment of phases

The assignment of the three phases of the mains power line should be carefully distributed to the different sorts of equipment in the studio. If this is left to chance, it is likely that you have to deal with many avoidable problems. There is one basic rule. Put all audio equipment on one phase and DON'T install any household appliance to this phase. Mark all sockets of the 'audio phase' carefully and take care that there are enough additional sockets that are connected to another phase. Of course, these sockets should also be marked. If you don't do so, you might have to deal with click noise, strange problems with noise or strange behavior of some systems every once in while. In a complex system, it is very difficult to figure out what the reason for a particular problem like this really is. Household appliance with temperature controls, switched power supply and ineffective filters, thermostats, relays and other components can cause this.

This principle gives another advantage. If you have to deal with a mains supply that is already 'dirty', since there are companies in the neighborhood that have huge power consumption and produce interference, you can single out the best phase for audio, just by rearranging the phases in your distribution panel –

AND AGAIN, THIS MUST BE DONE BY A QUALIFIED ELECTRICIAN AND IN ACCORDANCE WITH ALL SAFETY REGULATIONS IN YOUR LOCAL AREA.

Inrush current

As the power supply units of the broadcast consoles have a very high inrush current, precautions are necessary that concern the mains fuses. The actual inrush of the transformer is not the most important part of the total current. The power regulator circuits and the entire audio electronic of the console is a very huge capacitor that must be charged when the unit is switched on. This means that the current in the first moment is a lot higher than the quiescent current. For the mains power the console power supply is not different from a shortage at the moment when it is powered. The best way to handle this effect is to use an appropriate, slow blown mains fuse. Using conventional inrush current limiter, which is actually a relay in combination with a resistor, is not a good solution in our experience. If such systems are not 20 times oversized, it will become defective within the first two years. This is also the case with the electronic version that uses a triac or thyristor. As far as the BC4 consoles are concerned, a standard 16 amp slow blow fuse works fine with all power supply units including the UPS 1500 as long as one fuse is used for one power supply only and no additional equipment with high inrush current is connected to the same fuse.

1.5 Power Supply Connections – Power Supply Unit – Console

Cables

High cross section control wires connect the power supply units to the console. The cables are standardized and use DIN41618/41622 multipin connectors. All connectors are coded in a way that makes it impossible to incorrectly install a connector. The console's power supply connector is installed in the main connector behind the master section.

Important:

Please, do not plug in the cable between power supply and console when the power supply is already on. Nothing will become defective if you do so, but it is possible that protective circuitry in the power supply will record an overload and drops the voltage. If this happens, switch off the power supply, wait approximately 30 seconds and switch on again.

Cable length

The cables that are usually used are high cross section multicore cables with 18 or 26 conductors and a cross section between 1 mm² and 1.5 mm², depending on the size of the console. While the UPS600 and UPS1000 power supply units use a 20-pin connector a 26-pin connector is used for the UPS1500. Two connector pins and two cable lines are used in parallel for the high current supply voltages, audio +, audio – and relay & lamps to keep the voltage drop on the power lines as low as possible.

Since the total current consumption of the audio supply is in any case below 200 mA per module with standard mono input modules and mono group modules, unless all outputs are, loaded with 600 ohms and have full level, which is not a realistic assumption, a 56/8/4 version has a total audio supply current of less than 14 Amps. The constant output current of the UPS1500 with appropriate cooling is 18 amperes; the peak current is 21 amperes. For the high current supplies, the cross section of each line is 3 mm. This is equivalent to a resistance of 6 milliohms per meter. Since the total length of the cable must be multiplied by two, because the current must return to the power supply, a cable length of 12 meter is equivalent to a total resistance of 24 meter x 6 milliohms = 0.144 ohms. With a current of 14 ampere, the voltage drop with a 12 meter cable is approximately 2 Volts. This is the maximum voltage drop that should appear on the cable; therefore, the length is limited to 12 meter. If longer cables are required, there are three possible ways.

1. Using special cables with higher cross section. The problem with this solution is that appropriate cables are normally not available from stock, since they are not commonly used. A special order will have a very long lead-time and the minimum order quantity will be not reasonable.
2. Making a cable by using single wires of higher cross section for the 6 high power lines and normal cross section for the low current lines. This is of course possible, however, all the single cables must be coated by an appropriate cable hose. In total, it is going to be very expensive.

- If the cable length can be determined with the order, it is possible to install special power connectors with the power supply or the cross over device and the console's frame. In this case, we use an additional connector for the two high current audio lines only. Using a 26 line / 1.5 mm² cable means that 6 1.5 mm² lines can be used for the 4 high current audio lines in parallel. This results in a cross section of 10 mm² per line and in a total length of the cable with the 56/8/4 version of approximately 36 meters.

For several reasons, version 3 is the best choice, since the cost is much lower than version 2. In addition, there are no problems to put all the high cross section line into the cable housings. In our experience, a length in that range is more than sufficient. Actually, it happened only twice in more than 25 years that a longer cable was needed. By the way, we solved this problem with a huge 64 channel 5MT Broadcast where the location of the main gear room with the power supplies was 55 meters away from the control room, by using 4 connectors in total instead of two. Of course, if the console is a 32-channel version, the current is much lower and the maximum cable length can be higher. You can determine the maximum cable length for a particular console easily. It is reciprocally proportional to the number of channels. In detail: a 56/8/4 has 70 units, master section included. A 40-channel console with 8 groups has 54 modules in total. 70 divided by 54 is 1.3; and 1.3 multiplied by 12 meters is 15.5 meters. This console can have a maximum cable length of 15.5 meter. Of course, a 'version 3', dual connector installation can have a length of 47 meters without problems.

1.6 The pinning of the power supply plugs.

The drawing shows the pinning of the power supply connector if the BC4 console frame and the UPS1500 power supply unit that is used for larger versions of the BC4 system.

For smaller versions of the system, UPS1000 or UPS600 can be used. The pinning diagram of these power supply units can be found on the next page. These versions come with an adapted cable.

The cable power supply unit - console is part of the standard accessories of each console.



POWER CONNECTORS IN CONSOLE, POWER-SUPPLY AND CROSS-OVER UNITS

26 Pin DIN 41618/41622 Connector

Female in Power Supply - Male in Console Frame

VOLTAGE IN CONSOLE-FRAME MINIMUM MAXIMUM

(Minimum Voltage ist needed for Headroom + 26 dBu
Voltage may not exceed Maximum)



13	AUDIO +	24.5 V	25.5V	a b = +
12	AUDIO +	24.5 V	25.5V	a b = -
11	AUDIO -	24.5 V	25.5V	a b = +
10	AUDIO -	24.5 V	25.5V	a b = -
9	RELAIS	24.5 V	26.5V	a b = +
8	RELAIS	24.5 V	26.5V	a b = -
7	EXT-CTRL	23.5 V	24.5V	a=+ b=-
6	METER	23.5 V	25.5V	a=+ b=-
5	SPEAKER	18.0 V	20.0V	a=+ b=-
4	LOGIC	15.0 V	16.0V	a=+ b=-
3	P48	47.5 V	48.5V	a=+ b=-
2	nc			
1	CHASSIS / SL			

ALL SUPPLY VOLTAGES ARE FULLY FLOATING IN THE POWER SUPPLY UNIT AND THE CROSSOVER UNIT!
ALL VOLTAGES ARE MEASURED IN CONSOLE-FRAME
THE VOLTAGES IN THE POWER UNIT DEPEND ON CABLE LENGTH AND CURRENT CONSUMPTION OF THE CONSOLE

b = - a = +

POWER CONNECTORS IN CONSOLE, POWER-SUPPLY AND CROSS-OVER UNITS

20 Pin DIN 41622 Connector
Female in Power Supply - Male in Console Frame



	VOLTAGE IN CONSOLE-FRAME		MAXIMUM OUTPUT CURRENT IN UNIT	
	MINIMUM	MAXIMUM	UPS600	UPS1000
<small>(Minimum Voltage ist needed for Headroom + 26 dBu Voltage may not exceed Maximum)</small>				

10	AUDIO +	24.0 V	25.5V	3 A	5A
9	AUDIO -	24.0 V	25.5V	3 A	5A
8	RELAIS	24.5 V	26.5V	3 A	5A
7	EXT-CTRL	23.5 V	24.5V	1 A	1 A
6	METER	23.5 V	25.5V	3 A	5 A
5	SPEAKER	18.0 V	20.0V	1.5 A	1.5 A
4	LOGIC	15.0 V	16.0V	3 A	5A
3	P48	47.5 V	48.5V	0.1 A	0.1 A
2	nc				
1	CHASSIS / SL				

ALL SUPPLY VOLTAGES ARE FULLY FLOATING IN THE
POWER SUPPLY UNIT AND THE CROSSOVER UNIT!
ALL VOLTAGES ARE MEASURED IN CONSOLE-FRAME
THE VOLTAGES IN THE POWER UNIT DEPEND ON CABLE LENGTH
AND CURRENT CONSUMPTION OF THE CONSOLE

The pinning of the UPS600 and UPS1000 power supply units

2. Audio Installation in the Studio

2.1 Grounding

As already mentioned with the ground connection of the mains supply, correct and clean grounding in the entire studio is crucial for a proper and noise free operation of the entire system. We can not repeat this often enough – almost all common problems with poor S/N, humming, RF interference, which means, ‘I can hear the radio in my speaker, but where is the receiver’, and what is commonly called ‘Crosstalk’, which means that there is an audio signal on a channel where it is not supposed to be, has to do with bad grounding of the entire system.

It is a good idea to be concerned about several problems of a complex audio installation that are inevitably connected before the installation begins. Trouble free operation of a studio is dependent on the care that has been taken with the installation. In this regard, care does not mean the execution of the work has to be professional but also that the ground connections between the several parts of the entire system are appropriate and that the basic principle is carried out precisely in the complete installation.

To debate the entire topic will go beyond the scope of this manual. Therefore, we will concentrate on the essential parts.

The following basic principle is proven:

All cable screens are only connected on one end of a line. All screens are supposed to be connected to the screening pins of the console. All lines that are not directly connected to the console should have the screen connected to a central point that can be a patch bay or a distribution system.

This principle avoids ground loops thru additional ground connections thru the screens. All screen pins of all the audio connector of any adt-audio console are internally connected to a separate, isolated ground network that we call the connector ground. This connector ground is bridged to the main ground in the console at a point, where an external ground loop

causes the least possible problems. Of course, it is possible to use another basic principle, for instance, to connect the cable screens always at the input or the output of a device.

Connecting the screen to the inputs is problematic; it only works properly, if there are no lines that connect one output to more than one input. If such lines exist, care must be taken, to insure that the second input has no screen connection.

This problem does not exist if only the outputs have the screen connected. In this case, the screen potential is distributed with the audio signal and as long as the screen is not connected to an input, the system is free of ground loops. However, it is not possible to carry out the complete installation in this way. As soon as this principle is used with a phantom powered microphone input line, it has to be altered. The phantom supply current must return thru the screen of the cable. If the screen at the input is not connected, phantom power will simply not work anymore. This is the greatest disadvantage of the ‘output leads screen’ principle. If lines are used for microphone signals and other signals alternatively, this system becomes confusing. There is no way to avoid this confusion, unless microphone lines and microphone patch bays and distributors and other lines are strictly separated or the console’s phantom power system is replaced by local phantom power supply units that are installed next to each microphone. Actually, there is no real advantage using these two principles. The most transparent way is to connect all screens at the console.

By connecting the cable screens only on one end of the cable, it is possible to avoid ground loops in the entire system, as already mentioned above. However, this principle assumes that all devices are on the same ground potential. To accomplish this, it is necessary to add an additional grounding installation that connects all devices using high cross section cables to a central ground node in the studio. In most cases, the console is the best possible point for this ground node, since most of the audio lines in the studio are connected to the console. If this ground installation is carried out in a way, that each stand alone device and each rack with several devices is connected with a cross section of 4 to 10 mm² to this central ground node, the entire system is an excellent base for problem

free operation of the studio.

However, the problem with this principle is that electric safety has the highest priority. Since it is necessary to connect the protective conductor to every device that has a power line connection, there are actually two ground connections with almost every device, one thru the protective ground and the other one thru the additional, high cross section, ground cable.

Of course, this situation presents another risk for ground loops. At this point we have to get back to the considerations about the mains power installation to find a feasible solution since the modification of all the equipment in a studio, in a way that makes it possible to use the additional ground line as a protective conductor is impossible. In addition to the problem that occur with the necessary intrusion into the devices, and the connected legal problems, like warranty, etc. a modification like this also affects the safety of each device. The problem of which insurance company will underwrite this risk lead us to the point that this principle cannot be used.

However, there is a way that is much easier and works properly. If the mains power installation is executed in the way described above, we will already have a low impedance ground connection to the central ground node, which actually is the protective ground. We can leave everything unchanged, if we use this main ground line as not only audio ground node, but also as protective ground. Since the main ground conductor is part of the mains power installation it is not a problem to accomplish this system easily.

WE SHOULD MENTION THIS AGAIN...ONLY QUALIFIED PERSONNEL SHOULD BE ALLOWED TO INSTALL AND/OR MODIFY HAZARDOUS VOLTAGE, ELECTRICAL SYSTEMS.

THE EXAMPLES WE GIVE ARE VERY GENERAL AND ARE TO BE TAKEN AS SUCH; IN ADDITION, SOME DETAILS MAY NOT APPLY IN YOUR LOCAL AREA BECAUSE OF SPECIFIC LOCAL LAWS AND/OR REGULATIONS.

WE ADVISES THAT YOU CONSULT A QUALIFIED ELECTRICIAN REGARDING THE INSTALLATION OF ANY NEW ELECTRICAL SUPPLY, OR THE MODIFICATION OF AN EXISTING SUPPLY. BY NO MEANS, WILL WE BE LIABLE FOR ANYTHING THAT YOU DO.

Let's put this together. We use the high cross section ground line from the basement of the building not only as audio ground node but also as protective ground. If we now install additional, high cross section ground connections to the devices in the studio, we simply parallel the existing protective ground that already exists. If commonly used power cords and electric installation is used, we will have a cross section of the protective ground of 1.5 mm² from the electric distribution box to the sockets and 0.75 mm² to 1.5 mm² from the sockets to the devices. This differs from country to country, but it's always in the range. This cross section is sufficient for electric safety. Our additional high cross section cable add another 4, 6 or even 10 mm² just in parallel to the protective ground, which means, that the particular device is now connected to the ground node very well and that the protective ground is almost shorted by this additional ground line. However, if for any reason the additional ground is removed or fails, the original protective ground is still installed. Therefore, safety is not a problem. The only point of importance is that there may be no connection between the neutral conductor and the audio ground conductor, for the reasons already discussed in detail.

If, for any reason it is not possible to implement this system, there is another way to get the same result. However, this way is complicated and expensive. The entire mains power of the studio has to be separated from the mains power by a huge isolating transformer. When the isolation transformer is installed, the secondary circuit of the mains power is galvanically isolated from ground. The mains power has no ground reference anymore, which means, that we are free to apply any ground with a sufficient cross section as protective ground.

BEFORE USING THIS PRINCIPLE, MAKE SURE THAT YOUR LOCAL RULES ALLOW THIS PRINCIPLE. EVEN IF THIS WORKS, IT MIGHT NOT BE ALLOWED AT YOUR LOCATION.

For the realization, the main ground node, which in this case can be the central ground point of the building, or a separate earthing electrode, or a combination of both, has to be connected to the protective conductor at the studio installation that is driven by the secondary winding of the isolation transformer. As mentioned above, you must obey your local rules as far as the installation of isolation transformers are concerned. These rules are different from country to country. In some countries, it is only allowed to install one single device to an isolation transformer but not to install a system like this. Gather all necessary information and make sure that an installation like this is in accordance with the local safety regulations. Even if such system works properly, it is under your responsibility to obey the local rules and you will be liable for any damage and harm that is caused by this installation. By no means, we will be liable for anything that you do. We only describe possible ways of an audio installation, but we cannot tell if everything that is listed here is allowed at your location.

If your studio is installed in a room with an existing, old electrical installation, it is necessary to check this installation. Figure out, how the protective ground is wired and if it is connected to another electric circuit. Check if the cross section of the protective ground is appropriate and check how the different circuits and sockets are distributed among the fuses. If there is any connection of the protective ground to another room or sub distribution you will have serious problems. It is necessary to make sure, that the protective ground of the audio mains power is clean unless you risk many dubious problems. It might be necessary to replace cables, or add new protective conductors with sufficient cross section, replace sockets and rearrange the distribution and add new fuses. You need to have a skilled, professional electrician for this task, who is familiar with the special problems of audio installation and grounding.

2.2 Common grounding problems

Even if the principle of the ground installation is perfect, some common situations should be considered.

Video

This is the basic problem of any TV studio. Since all video connections are

unbalanced, it is a hard job to maintain clean audio ground situation with all the video equipment. You will need many audio transformers to make sure that your ground system is not polluted by the video signal. In many real-world situations, only pragmatism works, since you will not be able to make sure that an appropriate ground system can be installed. If this is the case, use the highest possible cross-section for any ground cable that is possible. If you cannot control the current in the different ground lines, the only possible way is to make the entire ground system as strong (as low a resistance) as possible.

Antennas

If a receiver or any other device is part of the system that requires a roof antenna, you can be sure that the antenna will inject a different ground potential into the system. An antenna must be grounded just for lightning protection and you can normally not control the ground potential of this antenna. Make sure that this will not affect your studio ground. If necessary, install audio transformers and isolate the entire device from the rest of the studio.

Computer network connections

Like video, the commonly used computer network connections of the RJ45 and 10-BaseT types are grounded on both sides of the line. A computer network installation is always a ground disaster, since all the computer devices, workstations, monitors, printers, network hubs, switches and repeaters may or may not be connected to a protective conductor, depending on the power supply of the particular device. In any case, all components are ground connected with the network cables, which have high impedance. Since it is not important for the function of the networks, no one takes care about the implementation of this ground connections at all. This is another way to spoil a good audio ground system.

Telephone lines and modems.

Any kind of telephone line or modem can create the same problem. In most cases, only audio transformers can be used to keep the ground system clean.

There is only one possible way to deal with these problems. After the installation is ready, tested and clean, check if there is any degradation

when one of these devices is connected to the system. If this happens, install audio transformers on the inputs and outputs of the device and use separate power lines to avoid pollution of the audio protection ground. If there is no degradation, you are lucky. Leave it as it is and make sure that you have a list of these devices ready. If at any time in the future you have noise in the system, disconnect all devices on the list before you start to disassemble the entire studio installation. There is always a very good chance that something that is not under your control has changed with one or more of these devices.

2.3 Cables

The selection of the cables that are used for the audio installation is very important for the proper operation of the entire system, for the sound performance and, last but not least for the cost of the installation. Multicore cables are commonly used for most of the necessary lines. There is an overwhelming offer of multicore cables from many brands in a price range from almost nothing to amounts that are not reasonable anymore.

As far as the sound performance of a cable is concerned, be aware of the fact that a cable does not 'sound'. A cable is a passive electric component that has a resistance, an inductance and a capacity, nothing else. If a cable alters anything, it depends not only on the cable itself but also on the qualities of the audio output and input that is connected with this cable. Since the electric properties of a cable are proportional to its length, longer cables are more critical than shorter cables. Nothing else but resistance, inductance and capacity is important for audio signals. The skin effect and the impedance have no influence on audio signals, because these effects are not relevant in the audio frequency band. The skin effect for instance is the influence of the magnetic field that is caused by any current in a conductor that displaces the electrons to the boundaries of the cable. It is obvious that this effect is proportional to the frequency of the signal, since it is caused by the inductive reactance that increases with the frequency. The skin depth is the distance from the boundary of the cable to that point inside the cable where the current is reduced by $1/e$, which is equivalent to 36.8 %. For audio signals at a frequency of 20 kHz, the skin depth is approx. 0.3 mm. With audio cables that usually have a diameter in the range of 0.2 to 0.4 mm this means, that there is simply

no skin effect. As far as the impedance or wave resistance of a cable is concerned, there is also no effect in the audio band. The meaning of the wave resistance is not so easy to understand. The speed of an electrical signal is in principal the speed of light. However, in a cable, the real speed of an electron is impeded. The real speed is in the range of two thirds of the speed of light. If we imagine a generator that is connected to one end of a cable and an output signal that is a pulse that is as small as possible, a so called Dirac pulse, the pulse runs thru the cable at approx. 200000 km/sec. For a certain period of time the pulse is only existing in the cable until it arrives at the input that is connected to the other end of the cable. Depending on the qualities of the cable, the pulse will be sent back to the output of the generator and produce reflexions of the original signal that run along the cable from end to the other if the wave resistance of the cable does not match the impedance of the connected input and output. If we use a cable of 100 meters, and assume that the speed is 200000 km/s we can calculate, that the time that is needed for the cable length of 100 meters is 500 nano seconds. The wavelength of an audio signal of 20 kHz is 0.050 ms, which is 100 times longer than the delay that is caused by the 100 m cable. This means, that even if there would be a reflection on the cable, it will not alter the signal, since the amplitude of the signal has not changed during the time between the original signal and the reflection. Actually, the phase angle difference of the 20 kHz signal during the 500 ns period is only 3 degrees.

The most important quality of a cable is the capacity. Since both lines and the screen are close together, the capacity of any cable cannot be neglected. We need to make a difference between the capacity core to core and core to screen. These two values have a different influence, depending on the type of audio connection. This means, that the core-to-core capacity is not that important with unbalanced signals. However, the lower the total capacity, the lower the possible influence. The most critical source is a microphone, since its source impedance is usually 200 ohms while the source impedance of professional audio line level outputs is below 60 ohms. Let's make some calculations to determine a critical value for the cable capacity. If you assume that the source resistance of the microphone is not higher than 200 ohms up to frequencies of 20 kHz, and we use a good quality cable with a total capacity (between cores and core to screen) of only 100 pF, we have a total load capacity of 10000 pF. This

capacity has an impedance of a little less than 800 ohms, which results in a drop of level at 20 kHz of approximately 0.75 dB and an additional phase shift in the range of 20 degrees. In critical situations, this will be audible. However, if the cable is shorter, or if a low source resistance line output is connected instead of the microphone, the situation is not that problematic. Anyway, we are supposed to check for low capacity values of the cables. The lower the capacity, the less chance there is of any possible influence on the audio signal.

While the inductance of commonly used cables is not important in the audio band, let's check if the resistance can have another influence. We use the 100 m microphone cable for this check again. If we use a cable with a cross section of 0.2 mm², the total resistance per core and per meter is approximately 0.085 ohms. The total length of both cores of the 100 m cable is of course 200 m, which means that the total resistance of such cable is 17 ohms. This resistance is added to the 200 ohms source resistance of the microphone, which means, that as far as the cable resistance is concerned, the input impedance of the amplifier is the important factor. A commonly used professional microphone preamplifier will have an impedance that is higher than 1 kOhm in any case. The difference in the attenuation of the applied load of a 1 kilohms input to a 200 ohm microphone can be easily calculated. Without cable, there is a voltage drop of 16 %, which is equivalent to approximately 1.3 dB. With the additional resistance of the cable the voltage drop is 16.4 % instead of 16 %. The difference is less than 0.1 dB, so we can forget about this, unless we use cables with a cross section that is much lower than 0.2 mm². This calculation also reveals, that the influence of silver plated cables is not existing. Even though the electrical conductance of silver is little better than the conductance of copper, the difference is not very high. Kappa, the electrical conductance of copper is 56.2 m/ohms*mm², while the conductance of silver is 62.5 m/ohms*mm². This makes a difference of 11.2 %. Since silver plated cables have only a very thin silver surface of less than 10 micrometers, the silver plating does not alter the total resistance of the cable at all. As we have already seen, also the skin effect, that would be able to make the silver-plating on the surface of the cable more important, will not have any effect in the audio band.

What is much more important than the material is, that the cable is stable

enough to withstand the mechanical treatment and that the isolation between the screen is sufficient to make sure, that there is no chance the screens of the separate cable in a multicore are shorted. This is a big risk with multicore cables that use anodized aluminum foil without additional isolation for the single lines. It is very difficult to assemble these cables in a way that there is no risk for shorting the screens. If the multicore lines must be split to several single connectors, this type of cable is not a good selection at all. If the single lines are not carefully isolated with shrink tube or other appropriate material, a little scratch in the aluminum foil can create a very confusing problem when a screen makes electrical contact with the housing of a device. Don't use this kind of cable.

2.4 Planning of the installation

A good design and preparation of the installation will save a lot of time and trouble. Make sure to list all the equipment that is installed in the studio and make a list of all necessary connections. In most cases, the biggest part of the work is not the console. All connections from a to the console are actually predetermined by the connectors. The major part of this work is the external processing gear in the control room and the connections from and to the studio. You must take care that you have enough connector panels in the studio and that these panels are placed in a way that can handle any kind of recording or broadcasting with the existing lines. In addition, studio headphones and playback speakers must be installed. Another part of the work is the necessary control installation, red lights, speakers' tables and anything else that is necessary for the particular studio.

External processing gear in the control room is the most problematic of any installation. All devices are different, you have to deal with balanced and unbalanced lines, different connectors types and problems with screening and grounding. In addition, the units that have internal power supply section can inject hum by the magnetic field of the power transformer into the devices that are mounted above or below in the rack. There are no standards for this kind of equipment, which means, that you have to figure out what works. In addition, there may be temperature problems in a rack, when several units with high operation temperature are mounted above each other. It is always a good idea to make some

tests before you make the rack layout and the cables.

Here are some proven rules:

Use only balanced cables

Even if a particular device is unbalanced, use a balanced cable. This gives the opportunity to transport the ground potential of the particular, unbalanced device to the balanced input of the console or another device. This means, that the balanced input 'sees' the voltage differential between the unbalanced output and the ground of the device and not the output to the ground of the console. Any difference in the ground potential of the console and the external device will not cause problems using these principles. Otherwise, the voltage difference between the two grounds becomes a part of the audio signal.

The rules in brief

Connect all cable screens to the console and leave the other end open
If an external device is balanced, connect both lines to hot and cold.
If the external device is unbalanced, connect the hot / + phase to the unbalanced input or output and the cold/- phase to the ground of the external device.

Connect the screen to that end of the cable that is attached to the console only.

While you actually don't know what ground potential a particular screen pin of a connector of an external device has, you know that all screen pins of the console has a clean ground potential that can be used for screening without problems. If the cable is not attached to the console but to a patch bay or distribution panel, prepare a similar system for the cable screens in that patch-bay.

Carrying out the installation

Most of the work is cable assembly, which has to be made carefully. Care must be taken not only about the soldering and the isolation but also of an appropriate pull relief and the mechanical stability of the cables and the connectors. Every cable should be carefully tested before it is installed.